

Think again

BAY
1

SCENARIO: walking your dog and 3 BGs think there going to take advantage of you.

START: hand, gun unloaded and holstered facing up range and ypu must kneel to shoot

STAGE PROCEDURE: T1- T3 while keeping a hold of your dog. Tac sec as if each one was advancing on you nthe the steel

Note: only 10 rounds in first mag

ALL IDPA RULES APPLY

SCORING: 8 rounds, Vickers count

TARGETS: 3 IDPA, 0 non-threat 2 steel

START-STOP: Audible– last shot

NOTES: Concealment not required.

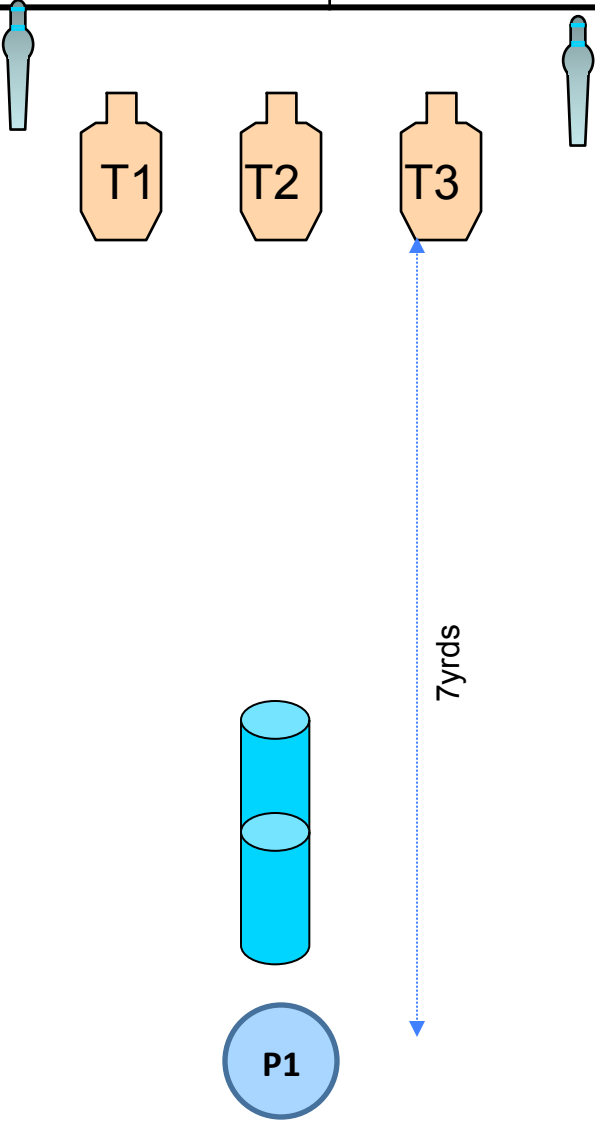

Boot Scoot n Boogie

BAY

2

SCENARIO:

START; At P1 Hands naturally at side. Gun loaded division capacity and holstered

ALL IDPA RULES APPLY

STAGE PROCEDURE: At Buzzer engage T1-T6 with 3 rounds each. One head shot required on all targets

SCORING: 18 rounds, Vickers

TARGETS: 6IDPA, 0 non-threat

Note: T1&T2 must be shot on the move. All reloads must begin and end behind cover.

START-STOP: Audible— last shot

NOTES: Concealment not required.

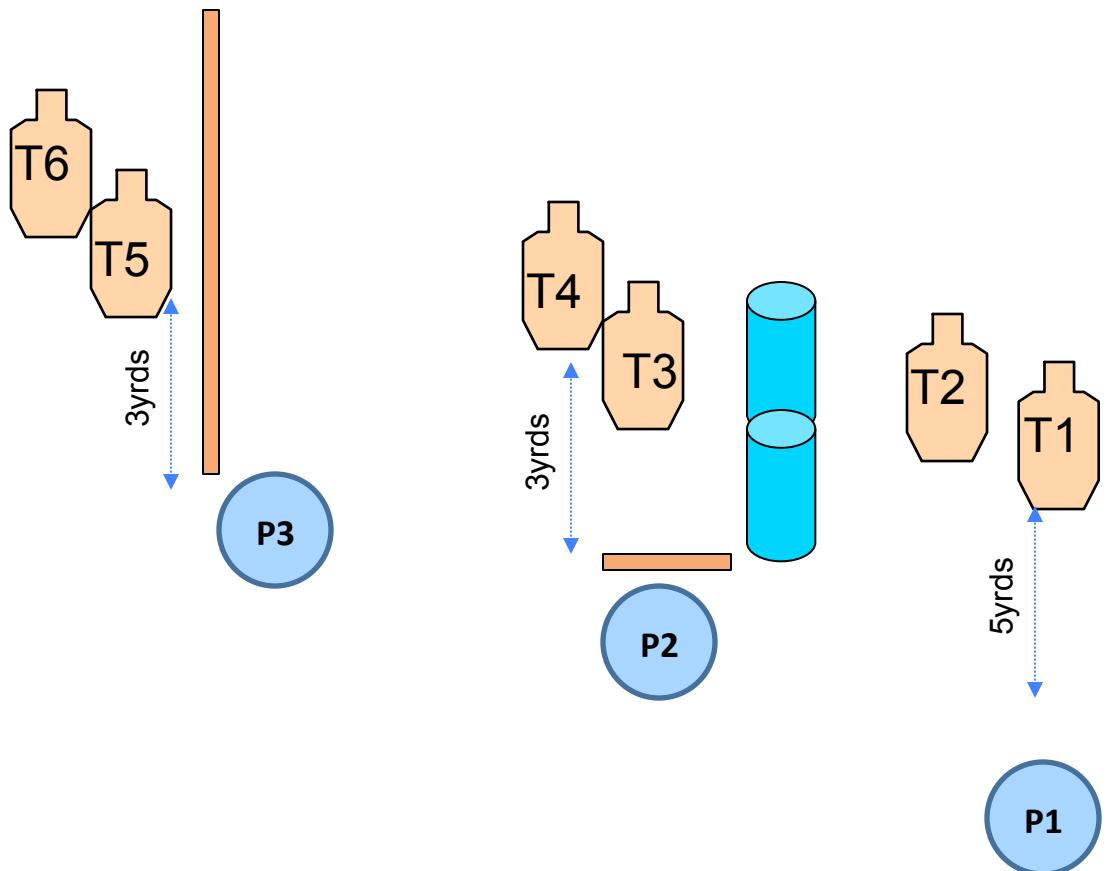

Short / Long

BAY

3

SCENARIO:

START; At P1 Hands naturally at side. Gun loaded division capacity and holstered

STAGE PROCEDURE: At buzzer engage T1-T4 with 2 rounds each on the move. At P2 engage T5 & T6 with 2 rounds each. Then steel

Note: Revolver shooters engage T4 from behind cover.

ALL IDPA RULES APPLY

SCORING: 13 rounds, Vickers

TARGETS: 6 IDPA, 2 non-threat one steel

START-STOP: Audible— last shot

NOTES: Concealment not required.

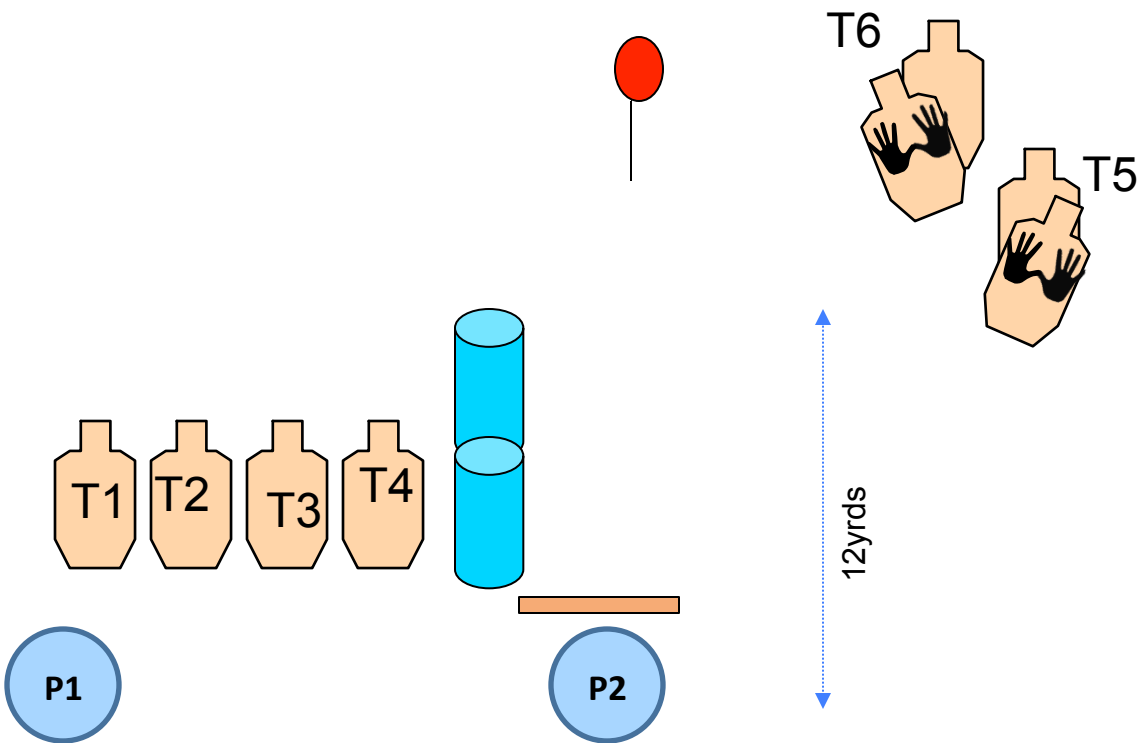

Too Many BGs

BAY

4

SCENARIO:

START; Gun loaded and in IDPA Box. Hands on knees. Back to back of chair, Sitting square to the desk. Box must be lid up.

STAGE PROCEDURE: At buzzer retrieve gun and engage T1 with 6 rounds while advancing to door. At P2 engage T2 –T6 with 2 rounds each tactical priority

Note:

ALL IDPA RULES APPLY

SCORING: 12 rounds, Vickers count

TARGETS: 6 IDPA, 2 non-threat

START-STOP: Audible– last shot

NOTES: Concealment not required.

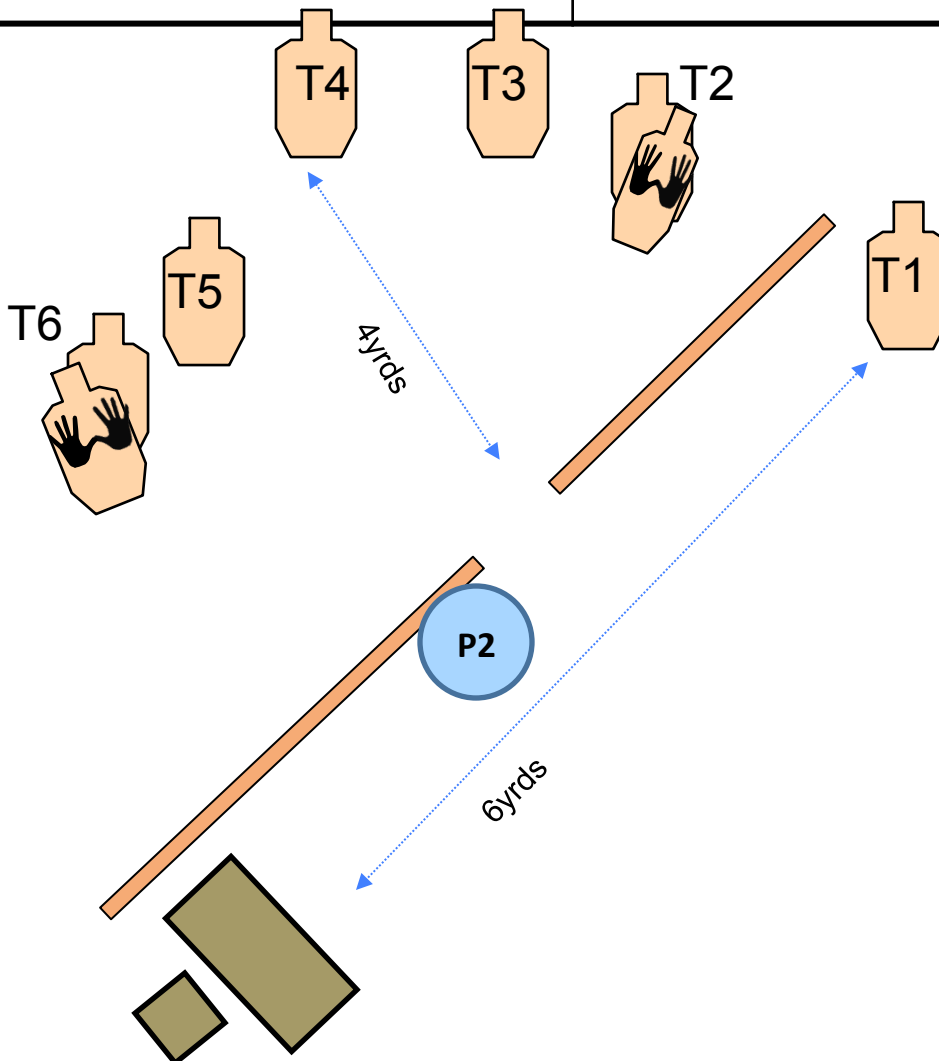

Broke down

BAY

5

SCENARIO: broke down on a back road and the driver has been taken hostage by some help gone bad

<p>START; At P1 Hands holding jumper cables underneath hood. Gun loaded division capacity and holstered</p>	<p>ALL IDPA RULES APPLY</p>
<p>STAGE PROCEDURE: At buzzer turn and engage T1-T6 in Tactical Priority (closest to furthest) with 2 rounds each.</p>	<p>SCORING: 12 rounds, Vickers</p>
<p>Note: Cover is not an option. All reloads must be emergency.</p>	<p>TARGETS: 6 IDPA, 2 non-threat</p>
	<p>START-STOP: Audible– last shot</p>
	<p>NOTES: Concealment not required.</p>

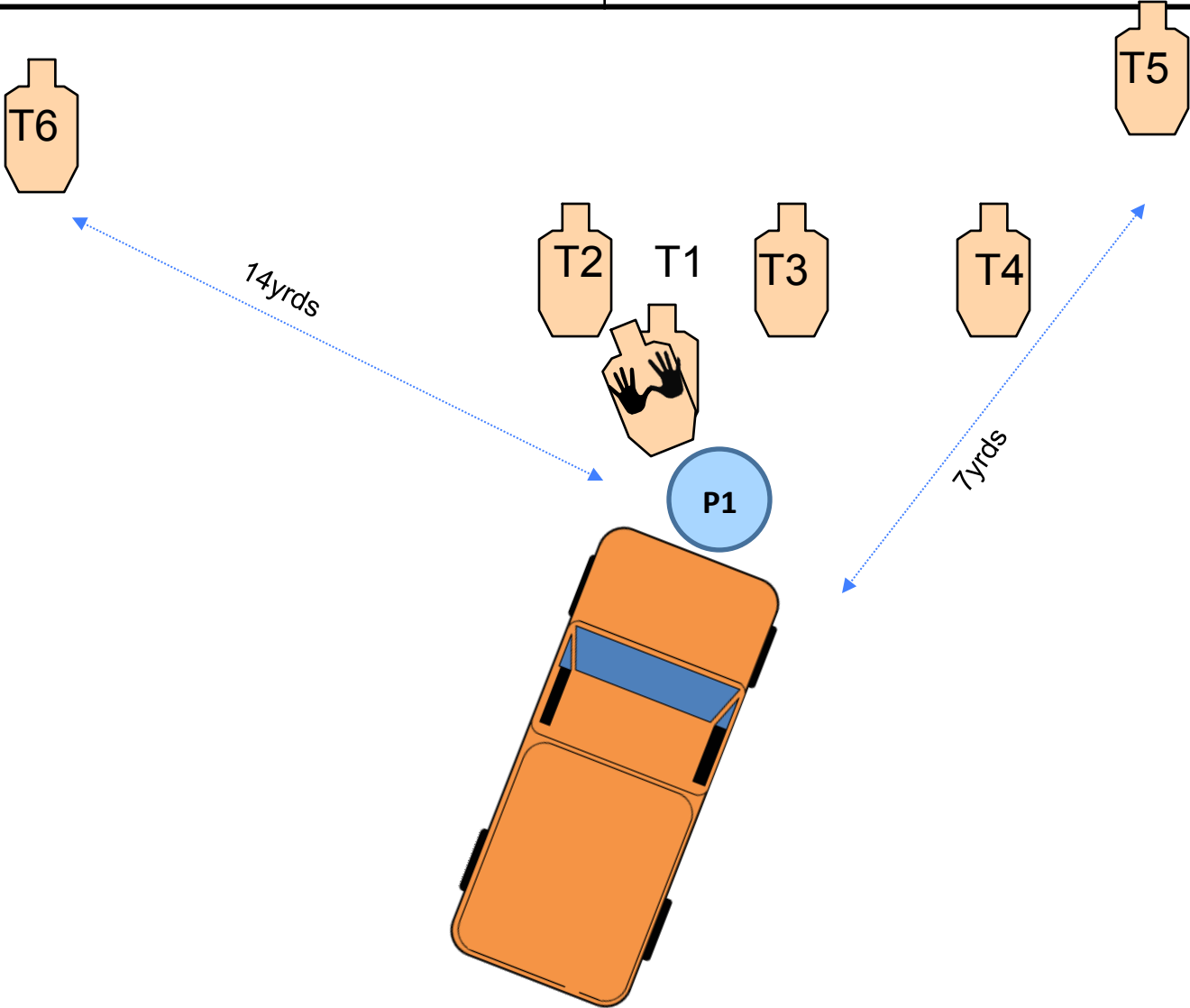

The Shoot Out

BAY

6

SCENARIO: while looking thru a window of your old house you see some bad stuff

START: Hand gun on barrel with magazines

ALL IDPA RULES APPLY

STAGE PROCEDURE: At buzzer retrieve handgun and engage T1—T6 with 2 rounds each in tactical priority then the star

SCORING: 17 rounds, Vickers

Have fun

TARGETS: 6 IDPA, 2 non-threat. star

Note:

START-STOP: Audible— last shot

NOTES: Concealment not required.

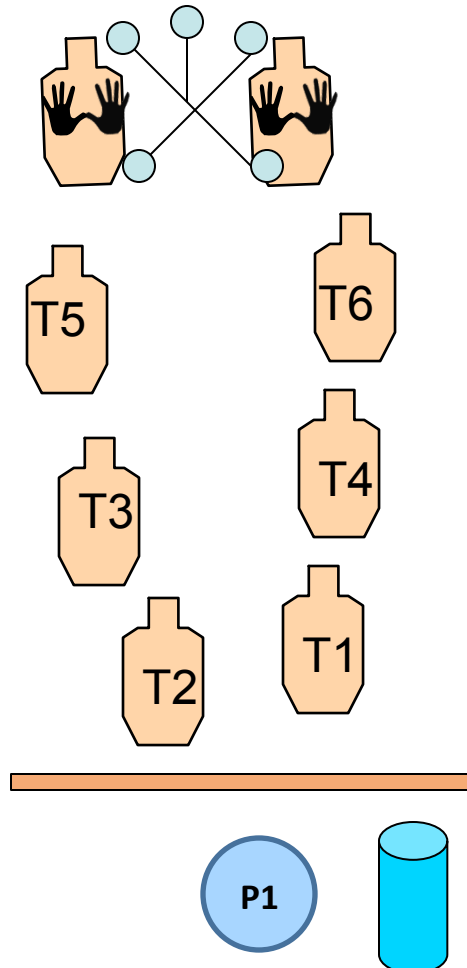

IDPA STAFF Date: 6-11-11

	SCENARIO	BUILDERS	SAFTEY OFFICERS	SCORE KEEPERS
BAY 1	Think Again		Derek	Mike & Michael
BAY 2	Boot Scoot n Boogie		Tom/Nathan	Kay
BAY 3	Short / Long		Teak	Charlie
BAY 4	Too Many BGs		Kim	Zach
BAY 5	Broke Down		Max	Butch
BAY 6	The Shoot Out		Donny	Reis

STAT HOUSE: Kay, Zach

MORE BUILDERS: Butch, Kim, Zach, Reis, Stephen,