

Midland Shooters Association
Avoidance Skills
Course Designer: Deane Durham

Bay
1

SCENARIO: Skills Drill. Your assailant is “gun-raised” at you, so you must make sideways movement as you bring your gun to target to avoid his aim and cause him to have to readjust sight picture. Shots can be fired standing still, but movement must be made between every shot.

GUN READY CONDITION: P1 with gun loaded and holstered.

STRINGS: 2
SCORING: 12 rounds min, Vickers
TARGETS: 6 threat, 0 non threat, 0 Steel
SCORED HITS: Best 2 per paper
START-STOP: Audible - Last shot
RULES: Current IDPA Rulebook
COVER GARMENT: Optional in summer

STAGE PROCEDURE: From P1, shooter engages targets L1-L3 while stepping to left side each shot with 2 rounds each. Reload and move off the clock. From P2, shooter engages targets R1-R3 while stepping to right side each shot with 2 rounds each. No round limit.

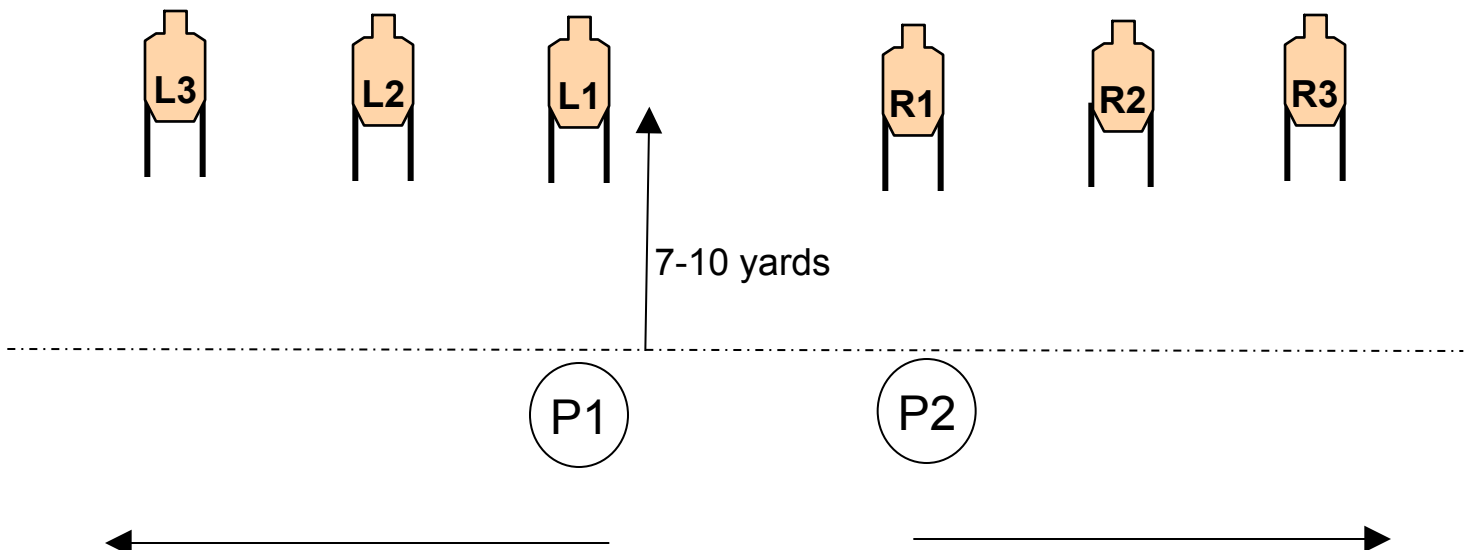

Midland Shooters Association

BAY
2

Course Designer:

SCENARIO: Skills Drill.

GUN READY CONDITION: P1 with gun loaded and holstered.

STRINGS: 1

SCORING: 18 rounds min, Vickers

TARGETS: 9 Threat, 0 non threat, 0 Steel

SCORED HITS: Best 2 per paper

START-STOP: Audible - Last shot

RULES: Current IDPA Rulebook

COVER GARMENT: Optional in summer

STAGE PROCEDURE: Heels against barrel. At buzzer draw & engage targets as they become visible w/ 2 rounds each.

T5-9 must be engaged from cover.

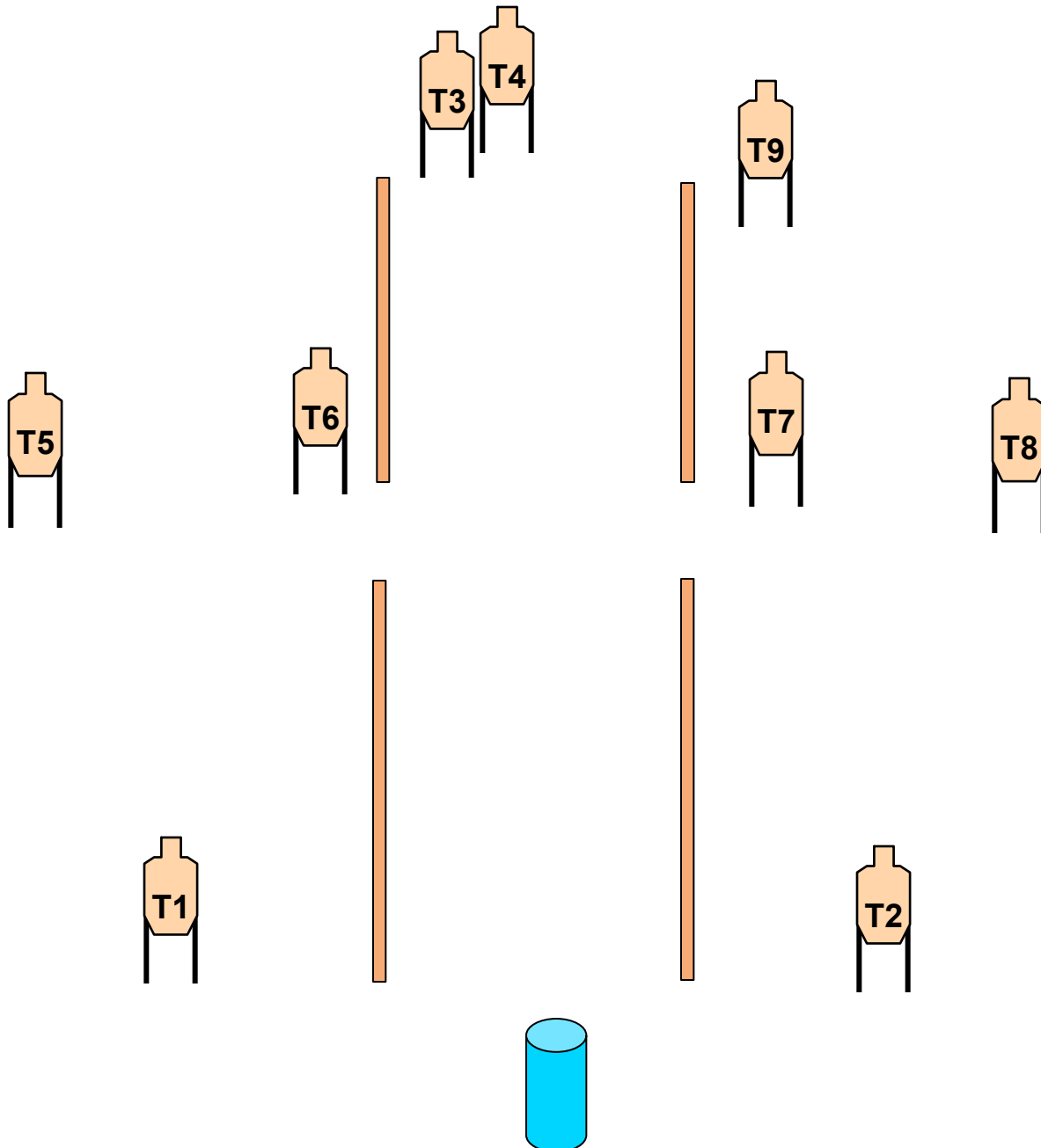

Eliminate the Threat

Course Designer: Deane Durham

SCENARIO: You are having a good time at home with the family when 8 BGs come from your front from the alley. You generally have your CHG (concealed handgun) on you and you do today. All of the BGs have either a handgun or a knife and threatening the entire family. As you engage T1-T3 you hear someone calling for help on the other side of your yard.

GUN READY CONDITION: P1 with gun loaded to class capacity and holstered.

STRINGS: 1
SCORING: 8 rounds min, Vickers
TARGETS: 5 threat, 2 non threat, 3 Steel
SCORED HITS: Neutralize Targets – best round
START-STOP: Audible - Last shot
RULES: Current IDPA Rulebook
COVER GARMENT: Optional in summer

STAGE PROCEDURE: From P1, shooter engages T1-T3 while moving forward. Engage T4-T5 while moving to P2. From cover at P2 engage T7 and T6 in tactical priority. Moving toward P3 engage T8. T5 activates T6. T7 is a steel reactive target set on the “head” setting. Any legal IDPA reload.

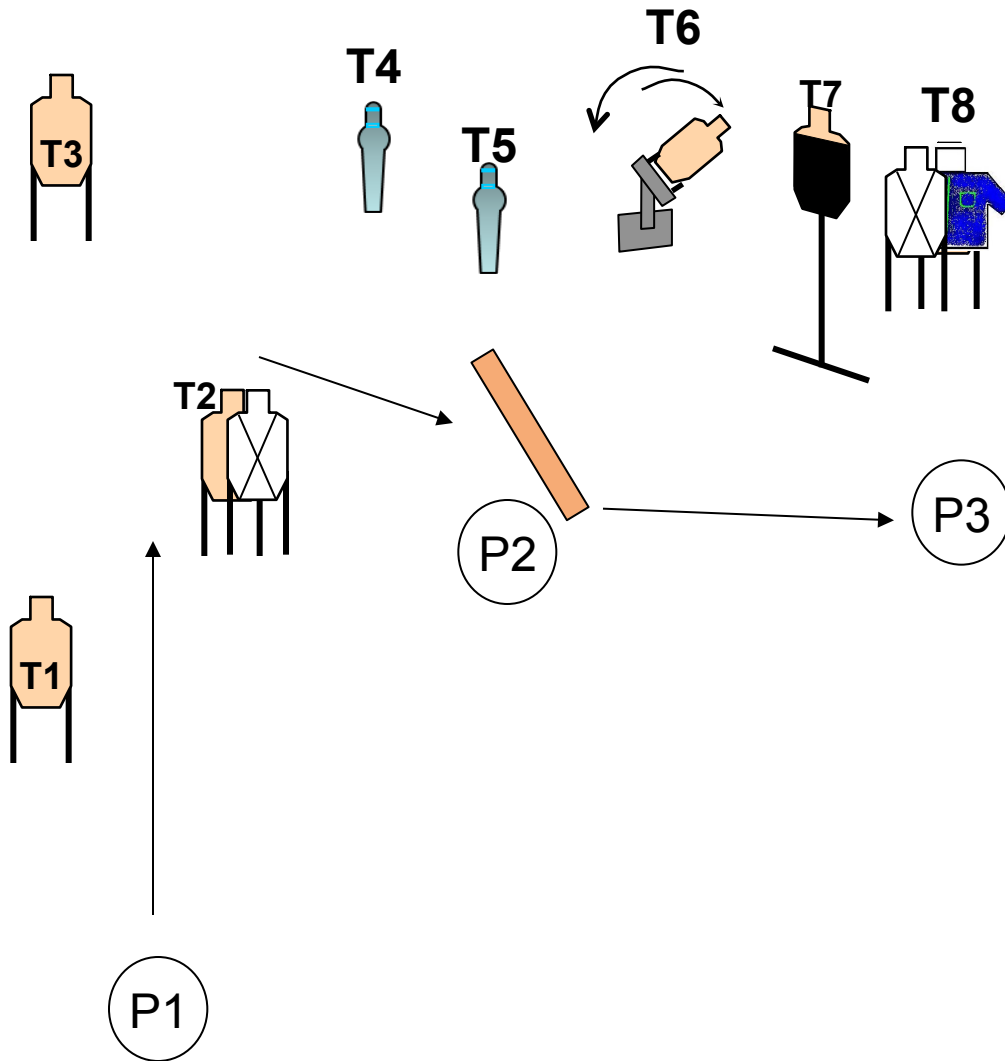

Pizzeria Attack

BAY

4

SCENARIO: You are at work when your pizza shop is attacked!!

START: Seated facing down range with both hands on barrel. Gun loaded and holstered.

STAGE PROCEDURE: At buzzer engage T1-T6 with 2 rounds each. Move to P2 and engage T7 and T8 with 2 rounds each.

ALL IDPA RULES APPLY

SCORING: 16 rounds, Vickers count

TARGETS: 8 IDPA, 2 non-threat

START-STOP: Audible— last shot

NOTES: Concealment not required.

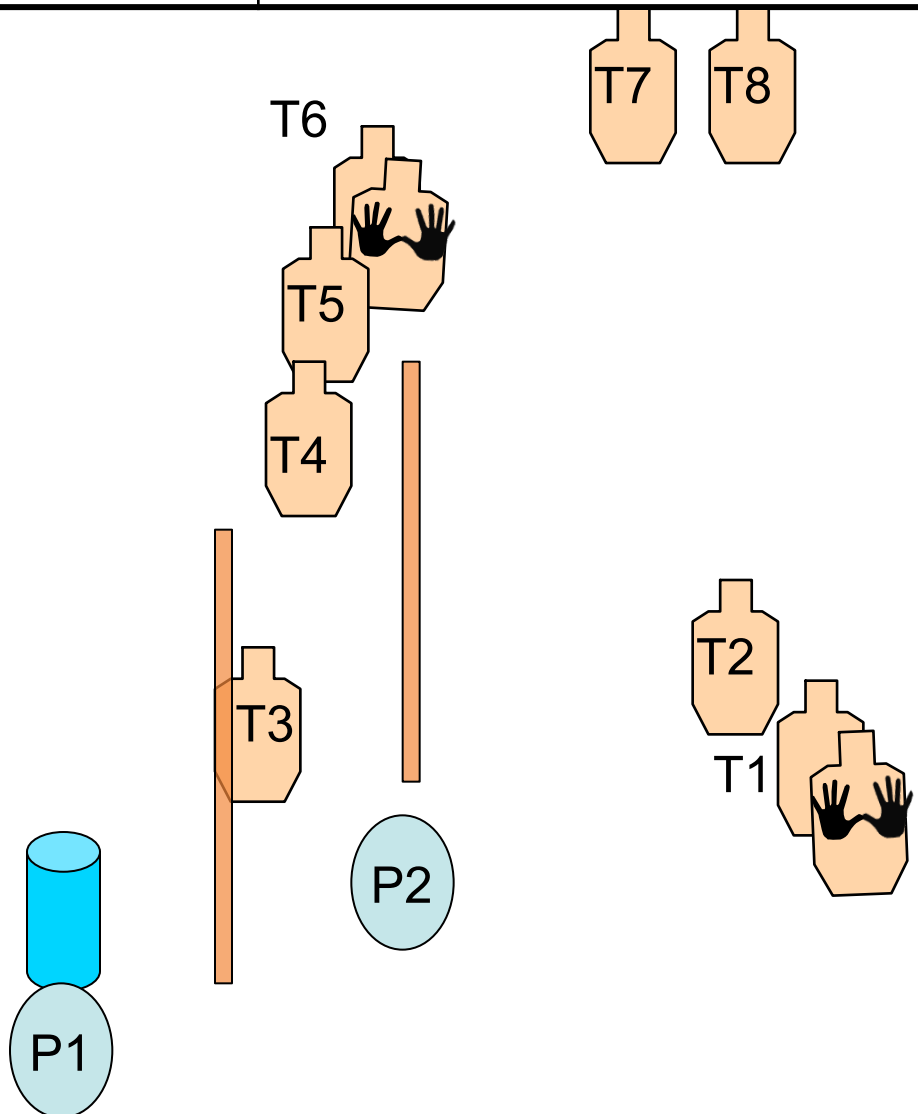

Midland Shooters Association

Course Designer:

Bay
5

SCENARIO:

GUN READY CONDITION: Loaded with 6 rounds in toolbox. Extra magazines in toolbox. Lid closed.

STAGE PROCEDURE: Under truck on creeper. Strong hand on wrench, weak hand on truck. Head and shoulders under truck. At buzzer drop wrench, roll out, retrieve gun and engage T1-6 with 2 rounds each in tactical sequence.

STRINGS: 1
SCORING: 12 rounds min, Vickers
TARGETS: 6 threat, 0 non-threat, 0 steel
SCORED HITS: Best 2 per paper
START-STOP: Audible - Last shot
RULES: Current IDPA Rulebook
COVER GARMENT: Optional in summer

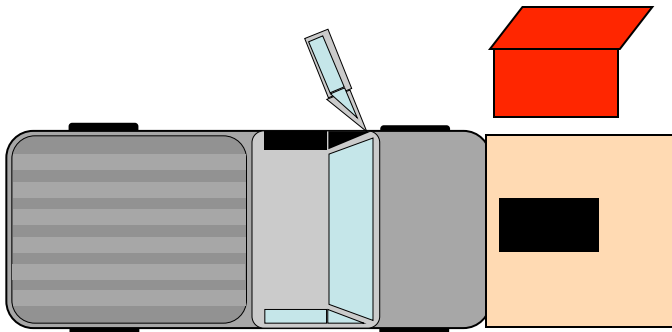
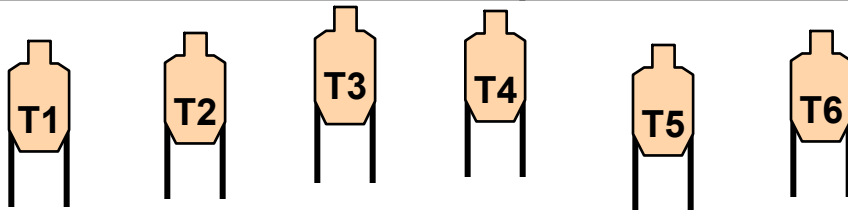

Midland Shooters Association

Course Designer: Rob Leatham

Bay
6

SCENARIO: Skills Drill.

GUN READY CONDITION: P1 with gun loaded and holstered.

STAGE PROCEDURE: At buzzer draw and engage T1-5 in any order. Mandatory reload at any time after first shot is fired and before last shot is fired.

STRINGS: 1

SCORING: 10 rounds min. Vickers

TARGETS: 5 threat, 0 non-threat, 0 steel

SCORED HITS: Best 2 per paper

START-STOP: Audible - Last shot

RULES: Current IDPA Rulebook

COVER GARMENT: Optional in summer

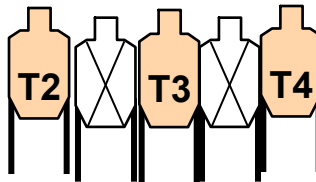

IDPA STAFF Date: 8/13/11

	SCENARIO	BUILDERS	SAFTEY OFFICERS	SCORE KEEPERS
BAY 1	Avoidance Skills	Bill/Morgan	Bill	Morgan
BAY 2		Teak	Teak	Kaye
BAY 3	Eliminate the Threat	Deane	Deane	Reis
BAY 4		Zach	Zach	Butch
BAY 5		Charlie/Kim	Charlie	Kim
BAY 6		Max/Kaye	Max	DIANN

STAT HOUSE: Paula

MORE BUILDERS: